



# MASSAGERS

**Food Processing Equipment Manufacturer**



Phone: [819] 395-5151 Fax: [819] 395-5343

Contact Us

**SIPROMAC INC. International Headquarters**  
240 Industrial Blvd, St-Germain  
Quebec, Canada J0C 1K0  
[www.sipromac.com](http://www.sipromac.com) / [sipromac@sipromac.com](mailto:sipromac@sipromac.com)

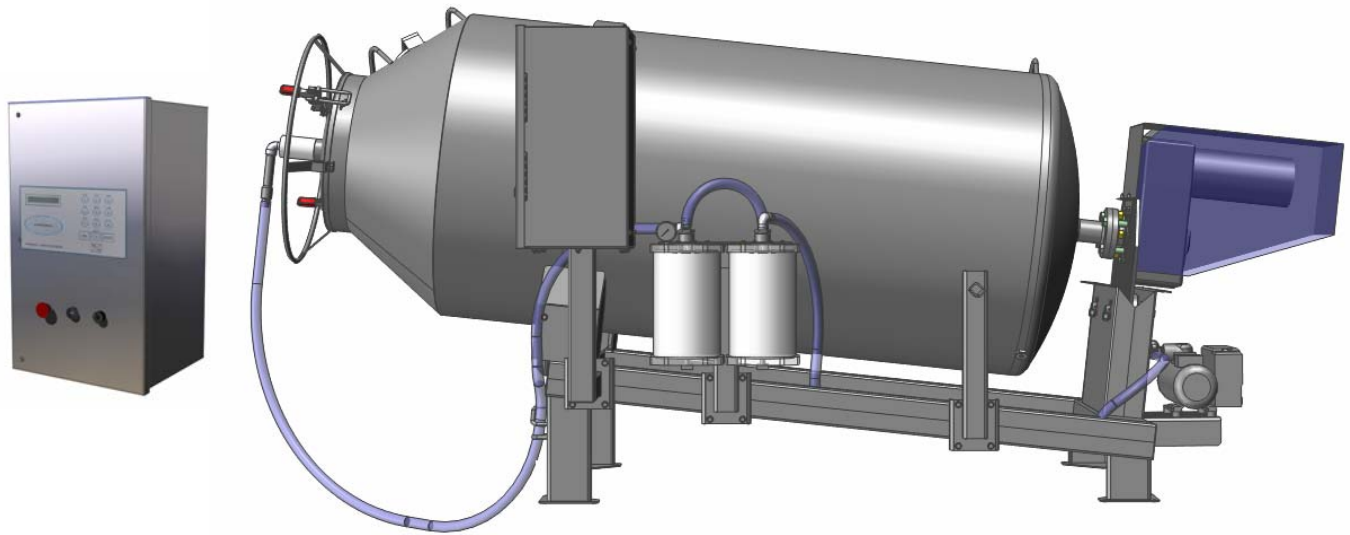

### STANDARD FEATURES

- Stainless steel welded construction
- Helicoidal paddle used for a perfect massaging action
- MC-40 computerized controls
- Reverse rotation to unload
- Front wheels for better rotation
- Direct drive system (no chains or belt)
- Double water separator system

### ADVANTAGES OF VACUUM MASSAGE

- Excellent water retention
- Color stability and consistency
- Higher homogeneity of products
- Overnight operations
- Great combination with Sipromac injector
- Prevents air pockets
- Improved distribution of brine
- Considerable increase in weight
- Time saving
- Maximum hygiene

### SPECIFICATIONS

Options: Cleaning door for inspection, loading system, adjustable legs, load cells

MODEL	VT 1000	VT 2000	VT 4000	VT 6000	VT 8000	VT 10000
CAPACITY (Lbs of cured meat)	1000	2000	4000	6000	8000	10000
Overall dimension (L x W x H) in.	106x73x76	155x74x73	166x85x83	181x90x87	206x90x87	203x94x91
Overall dimension (L x W) mm	2680x1834	3930x1876	4200x2160	4587x2264	5233x2264	5148x2387
(H) mm	1908	1850	2099	2195	2195	2308
Vacuum pump	21 m <sup>3</sup> /hr	40 m <sup>3</sup> /hr	63 m <sup>3</sup> /hr	100 m <sup>3</sup> /hr	100 m <sup>3</sup> /hr	160 m <sup>3</sup> /hr
Electrical power (kW)	2.0	3.3	4.7	7.7	9.6	13.5

*\*Sipromac reserves the right to make technical changes without notification*



240 Industriel Blvd.  
St-Germain, QC Canada J0C 1K0  
Phone: 819 395-5151  
Fax: 819 395-5343

www.sipromac.com  
sipromac@sipromac.com

**BUILT  
FOR  
LIFE**



**Food Processing  
Equipment Manufacturer**

www.sipromac.com

Authorized Dealer